

D

C

B

A

1  
2  
3  
4  
5

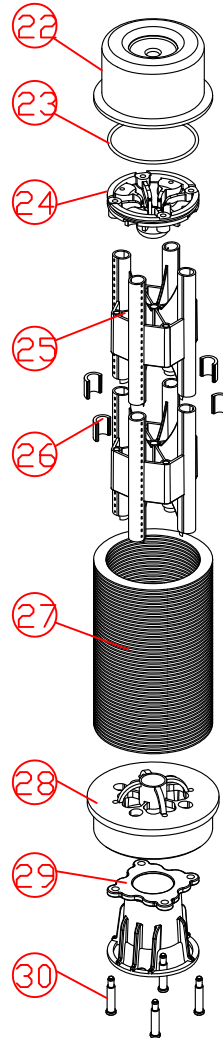
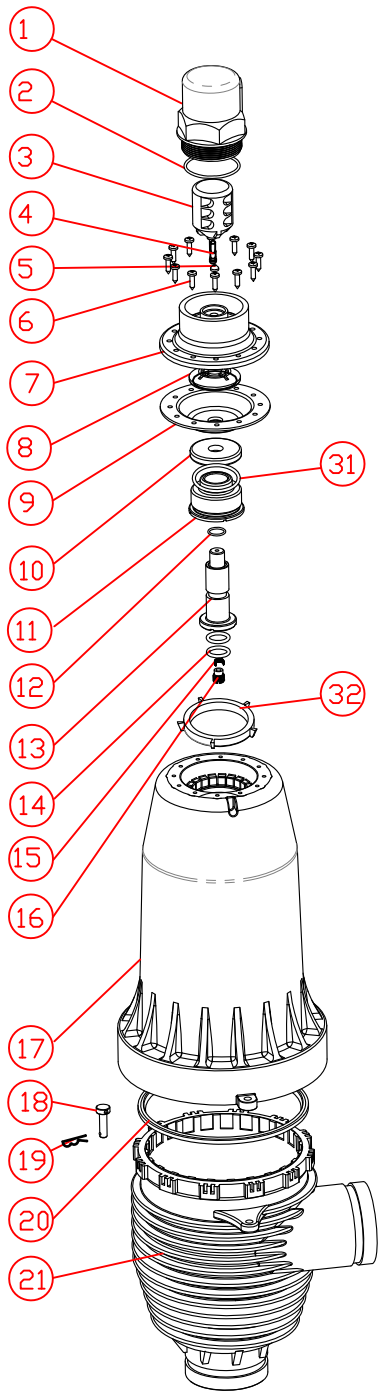

1  
2  
3  
4  
5

2 INCH DISC FILTER UNIT  
EXPLODED DRAWING  
(130 μ m)



|   |                      |                        |           |      |
|---|----------------------|------------------------|-----------|------|
| 6 | NUMBERS              | DESCRIPTION OF CHANGES | SIGNATURE | DATE |
|   | DRAWN BY/DATE        |                        |           |      |
|   | CHECKED BY/DATE      |                        |           |      |
|   | APPROVED BY/DATE     |                        |           |      |
|   | STANDARDIZED BY/DATE |                        |           |      |

|                       |          |              |       |
|-----------------------|----------|--------------|-------|
| REVISION              | QUANTITY | WEIGHT       | SCALE |
| 06                    | /        | /            | /     |
| UNREMARKED TOLERANCES | /        | SHEET 1 OF 2 |       |
| MATERIAL GRADE        | /        | /            |       |

D

C

B

A

