

D

C

B

A

1

2

3

4

5

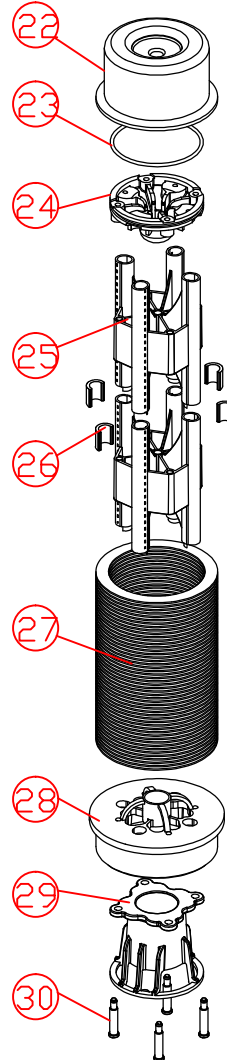
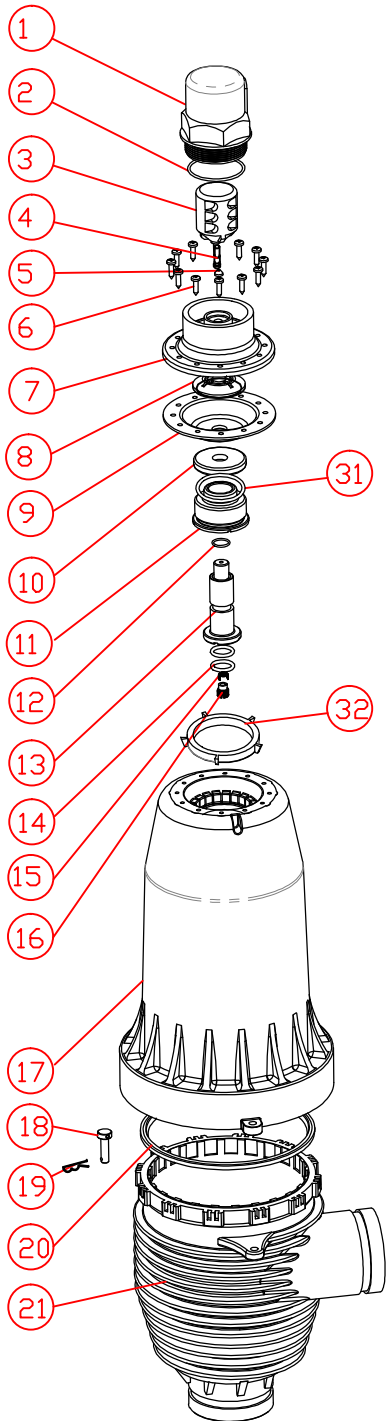

1

2

3

4

5

6

6

2 INCH DISC FILTER UNIT  
EXPLODED DRAWING  
(50 μ m)



NUMBERS	DESCRIPTION OF CHANGES	SIGNATURE	DATE
DRAWN BY/DATE			
CHECKED BY/DATE			
APPROVED BY/DATE			
STANDARIZED BY/DATE			

REVISION	QUANTITY	WEIGHT	SCALE
06	/	/	/
UNREMARKED TOLERANCES	/	SHEET 1 OF 2	
MATERIAL GRADE	/	/	

D

C

B

A

